

**SPECIFICATIONS**

CONTACT RATING: 100mA, 28V DC/AC max. ; 0.1mA, 20mV DC/AC min.  
 ELECTRICAL LIFE: 50,000 cycles  
 CONTACT RESISTANCE: 50mΩ max.(initial)  
 INSULATION RESISTANCE: 500MΩ min. 500VDC  
 DIELECTRIC STRENGTH: 500VAC/1 min.  
 OPERATING TEMPERATURE: -30°C to +85°C

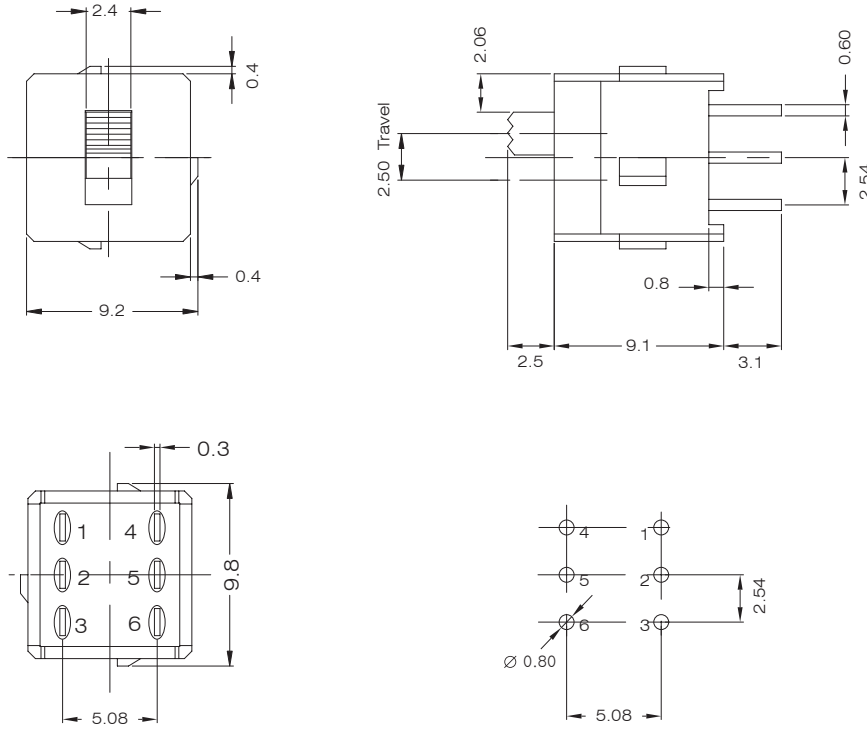

**HOW TO ORDER**

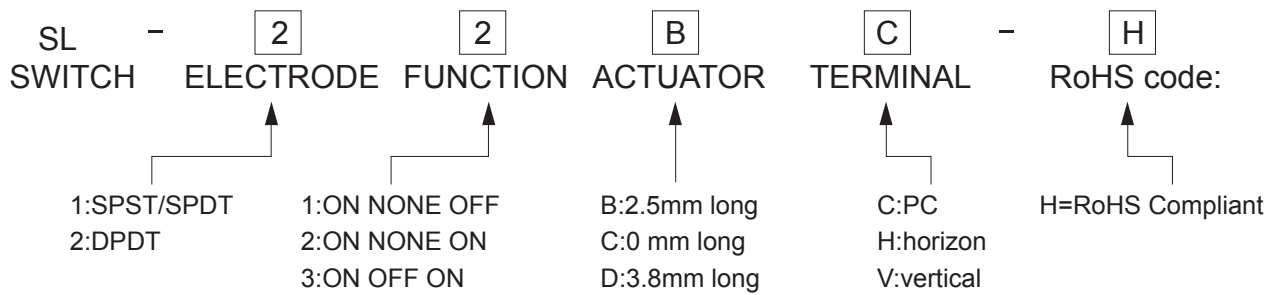

INDEX

TOGGLE

ROCKER

SLIDE

PUSH-BUTTON

DIP

TACT